



ARTESYN DS3000PE

High Line: 3000 W

Low Line: 1350 W

XXXX

DATA SHEET

Distributed Power Bulk Front-end

Single Output Standard

Total Output Power:

3000 W continuous

208 Vac to 264 Vac, 3000 W¹

90 Vac to 140 Vac, 1350 W

¹ 2700 W output rating at 180 Vac

SPECIAL FEATURES

- 3000 W output power
- High power and narrow form factor
- 6 units can fit in a 19" inch for a total of 16.2 kW
- High density design: 24 W/in³
- Active Power Factor Correction
- EN61000-3-2 harmonic compliance
- Inrush current control
- 80plus platinum efficiency
- N+1 or N+N redundant
- Hot-pluggable
- Active current sharing
- Full digital control
- PMBus compliant
- Accurate input power reporting
- Compatible with Artesyn's universal PMBus GUI
- Two-year warranty

COMPLIANCE

- Conducted/Radiated EMI EN55022 Class A Limits + 6 dB margin
- RoHS

SAFETY

- UL/cUL
- DEMKO+ CB Report EN60950
- BSMI
- CE Mark
- China CQC



ELECTRICAL SPECIFICATIONS

Input	
Input voltage range	90-140 Vac, 1350 W 208 to 264 Vac ¹ , 3000 W
Frequency	47 Hz to 63 Hz
Efficiency	94.0% peak
Max input current	17.5 Arms
Inrush current	55 Apk
Conducted EMI	Class A
Radiated EMI	Class A
Power factor	>0.97, typical
ITHD	10%
Leakage current	0.58 mA
Hold-up time	11 ms
Ordering Information	
DS3000PE-3	Standard Airflow
DS3000PE-3-001	Reverse Airflow

ELECTRICAL SPECIFICATIONS (CONTINUED)

Output			
Main DC Output	MIN	NOM	MAX
Nominal setting	-0.30%	12	0.30%
Total output regulation range	11.4 V		12.6 V
Dynamic load regulation range	11.4 V		12.6 V
Output ripple			120 mVp-p
Output current	2 A ⁴		250 A ⁵
Current sharing	Within +/-13.8 A of each other		
Capacitive loading	1,000 μ F		15,000 μ f
Start-up from AC to output			2100 ms
Output rise time	2 ms		60 ms
Standby DC Output			
Nominal setting	-1%	12.0 V	1%
Total output regulation range	11.4 V		12.6 V
Dynamic load regulation range	11.4 V		12.6 V
Output ripple			120 mVp-p
Output current	0.5 A		4.5 A
Current sharing		N/A	
Capacitive loading	47 μ F		560 μ f
Start-up from AC to output			1700 ms
Output rise time	2 ms		60 ms
Protections			
Main Output			
Overcurrent protection ²	104%		120%
Overvoltage protection ¹	13.5 V		15.0 V
Undervoltage protection	10.5 V		11.0 V
Overtemperature protection		Yes	
Fan fault protection		Yes	
Standby Output			
Overcurrent protection ⁴	110%		150%
Overvoltage protection ³	13.5 V		15.0 V
Undervoltage protection	9.6 V		11.0 V

¹ Latch mode

² Autorecovery if the overcurrent is less than 104% and last only for <500 ms.

³ Standby protection is auto-recovery

⁴ Minimum current for transient load response testing only. Unit is designed to operate and be within regulation range at zero load.

⁵ Reverse airflow model derates to 231.5 A

CONTROL AND STATUS SIGNALS

Input Signals			
PSON			
Active LOW signal which enables/disables the main output. Pulling this signal LOW will turn-on the main output. Recommended pull-up resistor to 12 VSB is 8.2 k with a 3.0 k pull-down to ground. A 100 pF decoupling capacitor is also recommended.			
		MIN	MAX
V _{IL}	Input logic level LOW		0.8 V
V _{IH}	Input logic level HIGH	2.0 V	5.0 V
I _{SOURCE}	Current that may be sourced by this pin		2 mA
I _{SINK}	Current that may be sunk by this pin at low state		0.5 mA
PSKIL			
First break/last mate active LOW signal which enables/disables the main output. This signal will have to be pulled to ground at the system side with a 220 ohm resistor. A 100 pF decoupling capacitor is also recommended.			
		MIN	MAX
V _{IL}	Input logic level LOW		0.8 V
V _{IH}	Input logic level HIGH	2.0 V	5.0 V
I _{SOURCE}	Current that may be sourced by this pin		2 mA
I _{SINK}	Current that may be sunk by this pin at low state		0.5 mA
A0, A1, A2			
Addressing pins of the power supply for I ² C communications. Refer to the addressing tables below.			
		MIN	MAX
	Internal pull-ups to 3.3V. It is recommended for the system to have pull-ups and decoupling on the address lines for better noise immunity.	R = 22 k ohm	C = 47 pF
V _{IL}	Input logic level LOW		0.8 V
V _{IH}	Input logic level HIGH	2.0 V	5.0 V
I _{SOURCE}	Current that may be sourced by this pin		4 mA
I _{SINK}	Current that may be sunk by this pin	4 mA	
Output Signals			
ACOK			
Signal used to indicate the presence of AC input to the power supply. A logic level HIGH will indicate that the AC input to the power supply is within the operating range while a logic level LOW will indicate that AC has been lost. This is an open collector/drain output. This pin is pulled high by a 1.0 k ohm resistor connected to 3.3 V inside the power supply. It is recommended that this pin be connected to a 100 pF decoupling capacitor and pulled down by a 100 k ohm resistor.			
		MIN	MAX
V _{IL}	Output logic level LOW		0.6 V
V _{IH}	Output logic level HIGH	2.0 V	5.0 V
I _{SOURCE}	Current that may be sourced by this pin		3.3 mA
I _{SINK}	Current that may be sunk by this pin at low state		0.7 mA

CONTROL AND STATUS SIGNALS (CONTINUED)

PWR_GOOD / PWOK			
Signal used to indicate that main output voltage is within regulation range. The PWR_GOOD signal will be driven HIGH when the output voltage is valid and will be driven LOW when the output falls below the under-voltage threshold.			
This signal also gives an advance warning when there is an impending power loss due to loss of AC input or system shutdown request. More details in the Timing Section.			
This is an open collector/drain output. This pin is pulled high by a 1.0 k ohm resistor connected to 3.3 V inside the power supply. It is recommended that this pin be connected to a 100 pF decoupling capacitor and pulled down by a 10 k ohm resistor.			
		MIN	MAX
V _{IL}	Output logic level LOW		0.8 V
V _{IH}	Output logic level HIGH	2.0 V	5.0 V
I _{SOURCE}	Current that may be sourced by this pin		3.3 mA
I _{SINK}	Current that may be sunk by this pin at low state		0.7 mA
PS_PRESENT			
Signal used to indicate to the system that a power supply is inserted in the power bay. Recommended pull-up resistor to 12 VSB is 8.2 k with a 3.0 k pull-down to ground. A 100 pF decoupling capacitor is also recommended.			
PS_INTERRUPT			
Active low signal used by the power supply to indicate to the system that a change in power supply status has occurred. This event can be triggered by faults such as OVP, OCP, OTP, and fan fault. This signal can be cleared by a CLEAR_FAULT command. Recommended pull-up resistor to 12 VSB is 8.2 k with a 3.0 k pull-down to ground. A 100 pF decoupling capacitor is also recommended.			
		MIN	MAX
V _{IL}	Output logic level LOW		0.8 V
V _{IH}	Output logic level HIGH	2.0 V	5.0 V
I _{SOURCE}	Current that may be sourced by this pin		4 mA
I _{SINK}	Current that may be sunk by this pin at low state		4 mA
BUS Signals			
ISHARE			
Bus signal used by the power supply for active current sharing. All power supplies configured in the system for n+n sharing will refer to this bus voltage in order to load share.			
Voltage Range	The range of this signal for active sharing will be up to 8.0 V, which corresponds to the maximum output current.		
		MIN	MAX
I _{SHARE} Voltage	Input logic level LOW	7.75	8.25
	Voltage at 50% load, stand-alone unit	3.85	4.15
	Voltage at 0% load, stand-alone unit	0	0.3
I _{SOURCE}	Current that may be sourced by this pin		160 mA
SCL, SDA			
Clock, data and addressing signals defined as per I2C requirements. The maximum system side resistor pull-up and decoupling capacitance			
		MIN	MAX
V _L	Logic level LOW		0.8 V
V _H	Logic level HIGH	2.0 V	5.0 V

Note: All signal noise levels are below 400 mVpk-pk from 0 - 100 MHz.

CONTROL AND STATUS SIGNALS (CONTINUED)

I ² C Addressing Table			
FRU ADDRESSING			
A2	A1	A0	Address
HIGH	LOW	LOW	0 x A9
HIGH	LOW	HIGH	0 x AB
HIGH	HIGH	LOW	0 x AD
HIGH	HIGH	HIGH	0 x AF*

PMBus Addressing
Address
0 x B8
0 x BA
0 x BC
0 x BE

* Default address when A0 and A1 are open

ELECTRICAL SPECIFICATIONS

LED Indicators			
	AC GOOD LED	DC GOOD LED	FAULT LED
Color	GREEN	GREEN	AMBER
No AC input to PSU	Off	Off	Off
AC present, STBY ON, main output OFF	On	Off	Off
Main output ON	On	On	Off
Power supply failure (OVP, OTP, FAN FAULT)	Off	Off	Blinking

Firmware Reporting And Monitoring			
	Accuracy Range		
Output loading	5 to 20%	20 to 50%	50 to 100%
Input voltage	±5%		
Input current	±0.55 A fixed error	±4%	
Input power	±10 W at < 100 W input	±5%	
Output voltage	±2%		
Output current	2.5 A fixed error	±2%	
Temperature	±5 degC on the operating range		
E _{IN}	±15% from 10% to 20% load	±5%	
Fan speed	±250 RPM		

PMBus	YES
Remote ON/OFF	YES

ELECTRICAL SPECIFICATIONS (CONTINUED)

Timing Specifications				
	Description	Min	Max	Unit
T_{sb_On}	Delay from AC being applied to standby output being within regulation	500	2000	ms
T_{sb_vout}	Delay from standby output to main output voltage being within regulation		1200	ms
T_{sb_ACOK}	Delay from standby output to ACOK assertion		40	ms
$T_{ac_on_delay}$	Delay from AC being applied to main output being within regulation		2200	ms
T_{pwok_on}	Delay from output voltages within regulation limits to PWOK asserted	100	1200	ms
T_{acok_delay}	Delay from loss of AC to assertion of ACOK		250	ms
$T_{pwok_hold-up}$	Delay from loss of AC to deassertion of PWOK	10		ms
$T_{vout_hold-up}$	Delay from loss of AC to main output falling out of regulation	11		ms
$T_{sb_Hold-up}$	Delay from loss of AC to standby output being within regulation	150		ms
$T_{PWR_GOOD_Off}$	Delay from deassertion of PWOK to output falling out of regulation	1		ms
$T_{PSON_On_Delay}$	Delay from PSON assertion to output being within regulation		350	ms

TIMING DIAGRAM

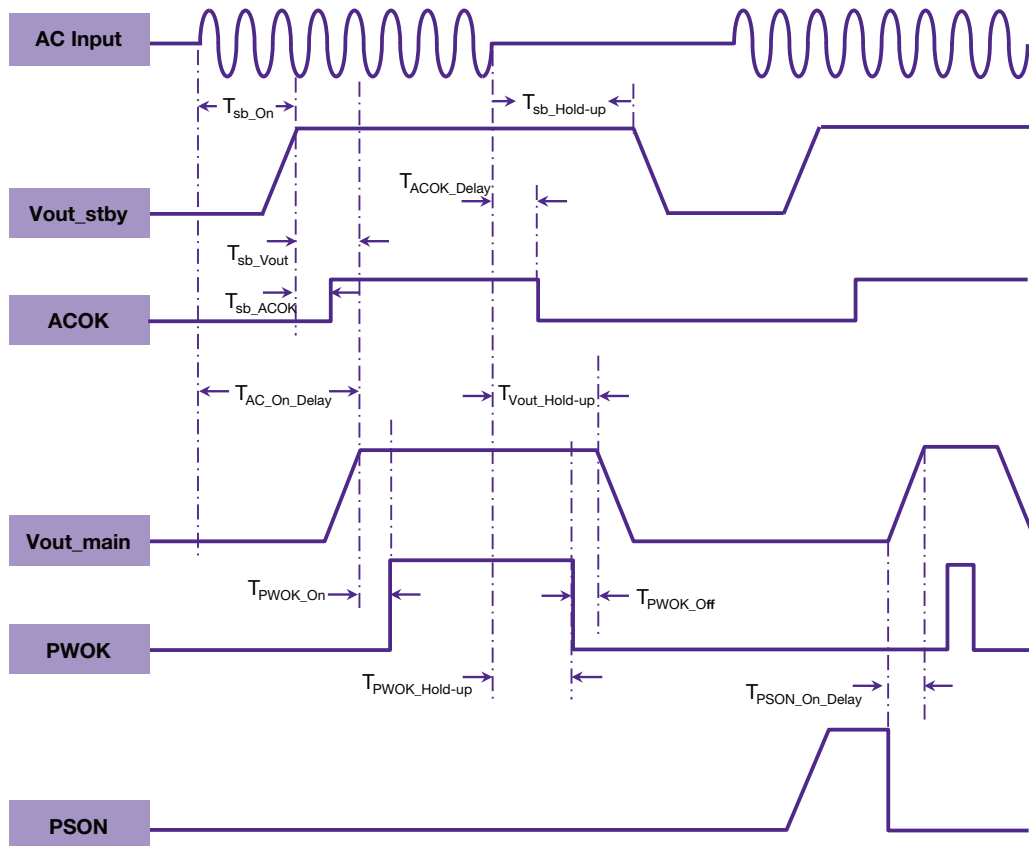

ENVIRONMENTAL SPECIFICATIONS

Operating temperature	Full power from 0 to 40 °C, derate output power by 2.5% per °C from 40 °C to 50 °C
Operating altitude	up to 10,000 feet
Operating relative humidity	20% to 80% non-condensing
Non-operating temperature	-40 to +85 °C
Non-operating relative humidity	10% to 95% non-condensing
Non-operating altitude	up to 30,000 feet
Vibration and shock	Standard operating/non-operating random vibration/shock
ROHS compliance	Yes
MTBF	400,000 hours
Operating life	Minimum of 5 years
Reliability	All electronic component derating analysis and capacitor life calculation is done at 25 degC ambient, maximum rated load, nominal input line voltage.

MECHANICAL OUTLINE

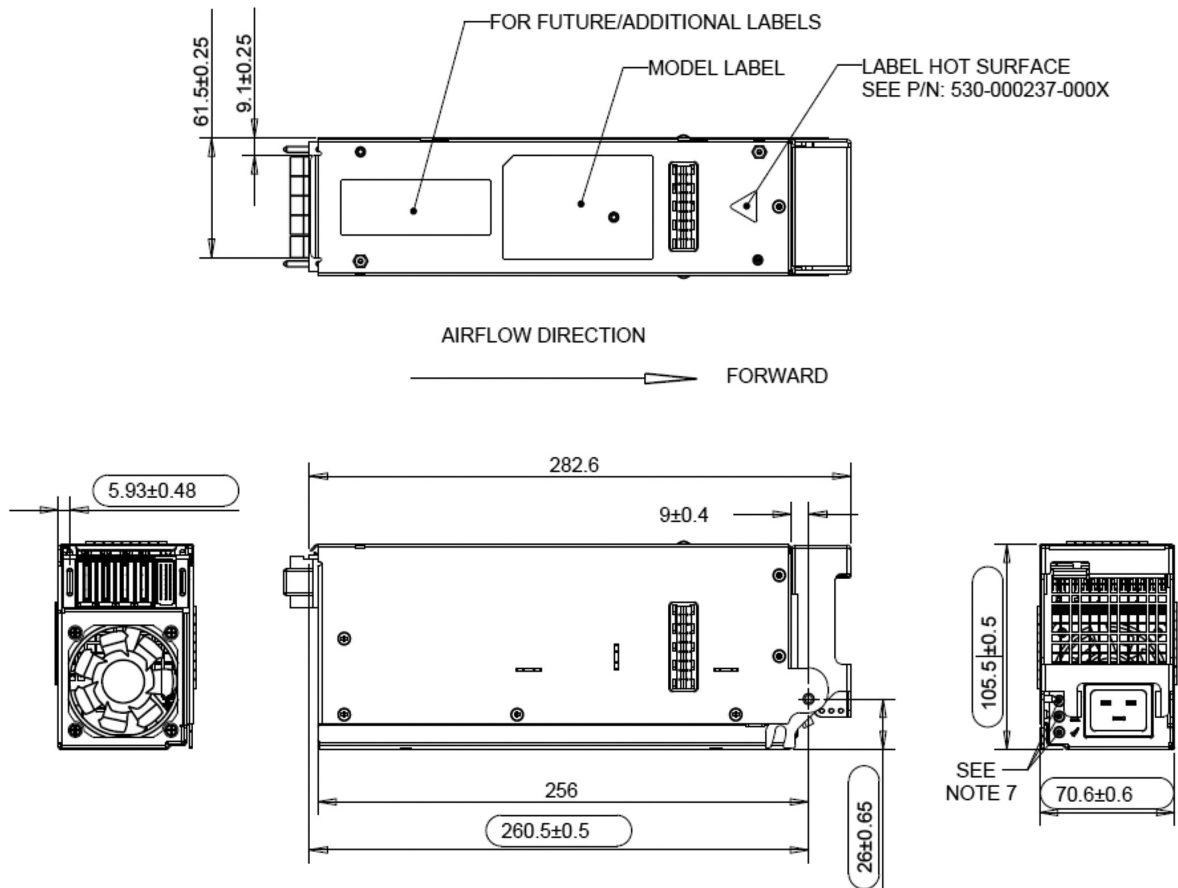

CONNECTOR DEFINITIONS

Output Connector Part Number	75555-104
Mating Connector Part Number	75541-104REVB1 or any other Molex recommended part

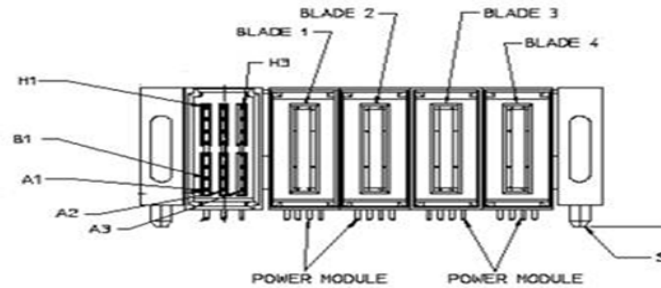

Pin	Signal Name	Amps per pin ¹
PB1	RETURN	150
PB2	RETURN	150
PB3	12 V	150
PB4	12 V	150
A1	PWR GOOD	N/A
A2	PSKILL	N/A
A3	PRESENT	N/A
B1	RETURN	N/A
B2	ISHARE	N/A
B3	RETURN	N/A
C1	PS_INTERRUPT	N/A
C2	RETURN	N/A
C3	ACOK	N/A
D1	RETURN	N/A
D2	PSON	N/A
D3	RESERVED	N/A
E1	SDA	N/A
E2	SCL	N/A
E3	A0	N/A
F1	RESERVED	N/A
F2	A1	N/A
F3	A2	N/A
G1	RESERVED	N/A
G2	RESERVED	N/A
G3	RESERVED	N/A
H1	12 VSB	2
H2	12 VSB	2
H3	12 VSB	2



For international contact information,
visit advancedenergy.com.

powersales@aei.com (Sales Support)
productsupport.ep@aei.com (Technical Support)
+1 888 412 7832

ABOUT ADVANCED ENERGY

Advanced Energy (AE) has devoted more than three decades to perfecting power for its global customers. AE designs and manufactures highly engineered, precision power conversion, measurement and control solutions for mission-critical applications and processes.

Our products enable customer innovation in complex applications for a wide range of industries including semiconductor equipment, industrial, manufacturing, telecommunications, data center computing, and medical. With deep applications know-how and responsive service and support across the globe, we build collaborative partnerships to meet rapid technological developments, propel growth for our customers, and innovate the future of power.

PRECISION | POWER | PERFORMANCE

Specifications are subject to change without notice. Not responsible for errors or omissions. ©2020 Advanced Energy Industries, Inc. All rights reserved. Advanced Energy®, AE® and Artesyn™ are U.S. trademarks of Advanced Energy Industries, Inc.